

PRODUCT INFORMATION PACKET

Model No: 213TTDBD6026

Catalog No: GT0016A

7.50 HP General Purpose Motor, 3 phase, 1800 RPM, 208-230/460 V, 213T Frame, ODP
Three Phase ODP Motors



Nameplate Specifications

Output HP	7.50 Hp	Output KW	5.6 kW
Frequency	60 Hz	Voltage	208-230/460 V
Current	21.2-19.8/9.9 A	Speed	1766 rpm
Service Factor	1.15	Phase	3
Efficiency	91 %	Power Factor	79
Duty	Continuous	Insulation Class	F
Design Code	B	KVA Code	H
Frame	213T	Enclosure	Drip Proof
Thermal Protection	No	Ambient Temperature	40 °C
Drive End Bearing Size	6307	Opp Drive End Bearing Size	6206
UL	Recognized	CSA	Y
CE	Y	IP Code	22

Technical Specifications

Electrical Type	Squirrel Cage Inverter Rated	Starting Method	Line Or Inverter
Poles	4	Rotation	Reversible
Resistance Main	1.698 Ohms	Mounting	Rigid Base
Motor Orientation	Horizontal	Drive End Bearing	Ball
Opp Drive End Bearing	Ball	Frame Material	Rolled Steel
Shaft Type	T	Overall Length	17.52 in
Shaft Diameter	1.375 in	Shaft Extension	3.38 in
Assembly/Box Mounting	F1/F2 CAPABLE		
Connection Drawing	EE7308	Outline Drawing	SS620684

This is an uncontrolled document once printed or downloaded and is subject to change without notice. Date Created:06/01/2021

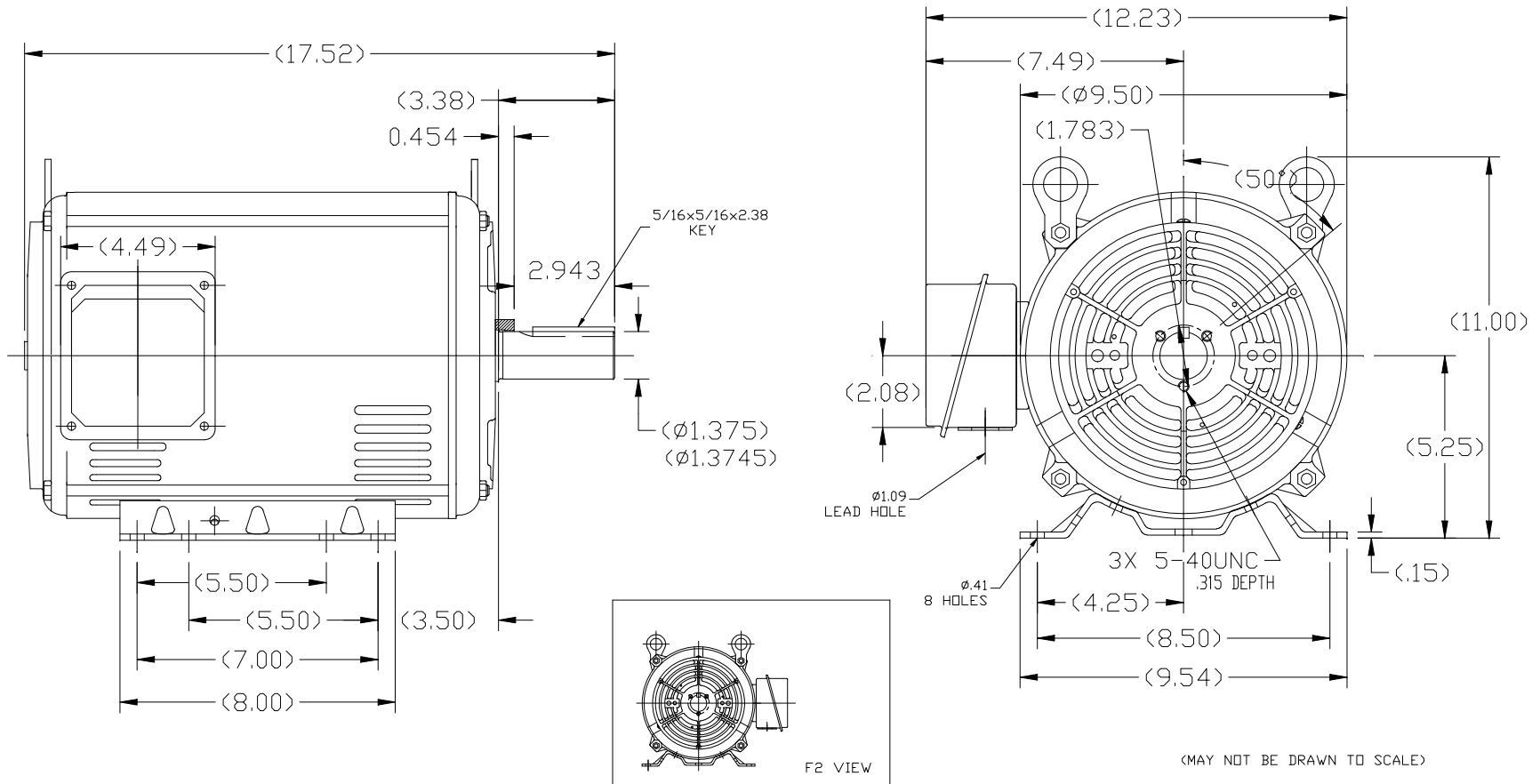

		TOLERANCES UNLESS SPECIFIED		REGAL REGAL-BELOIT CORPORATION		DRAWN ZXW 04-16-2015	
		DEC.	INCHES			CHK ZL 04-16-2015	
		X	±.1		APPD ZYH 04-16-2015		
		.XX	±.03	TITLE	OUTLINE		
		.XXX	±.005	213/215T ODP-ROLLED STEEL			
03	F2 VIEW ADDED PER ECO-0162175	NK	02-20-19	VY	.XXXX	±.0005	MAT'L
NO.	REVISION	BY & DATE	CHK	ANG	±1/2"	FINISH	PREV
THIS DRAWING IN DESIGN AND DETAIL IS OUR PROPERTY AND MUST NOT BE USED EXCEPT IN CONNECTION WITH OUR WORK ALL RIGHTS OF DESIGN AND INVENTION ARE RESERVED THIS IS AN ELECTRONICALLY GENERATED DOCUMENT - DO NOT SCALE THIS PRINT				RFP	CAD FILE		SS620684
				DIST	SIZE	DRAWING NO.	REV.
					B	SS620684	3

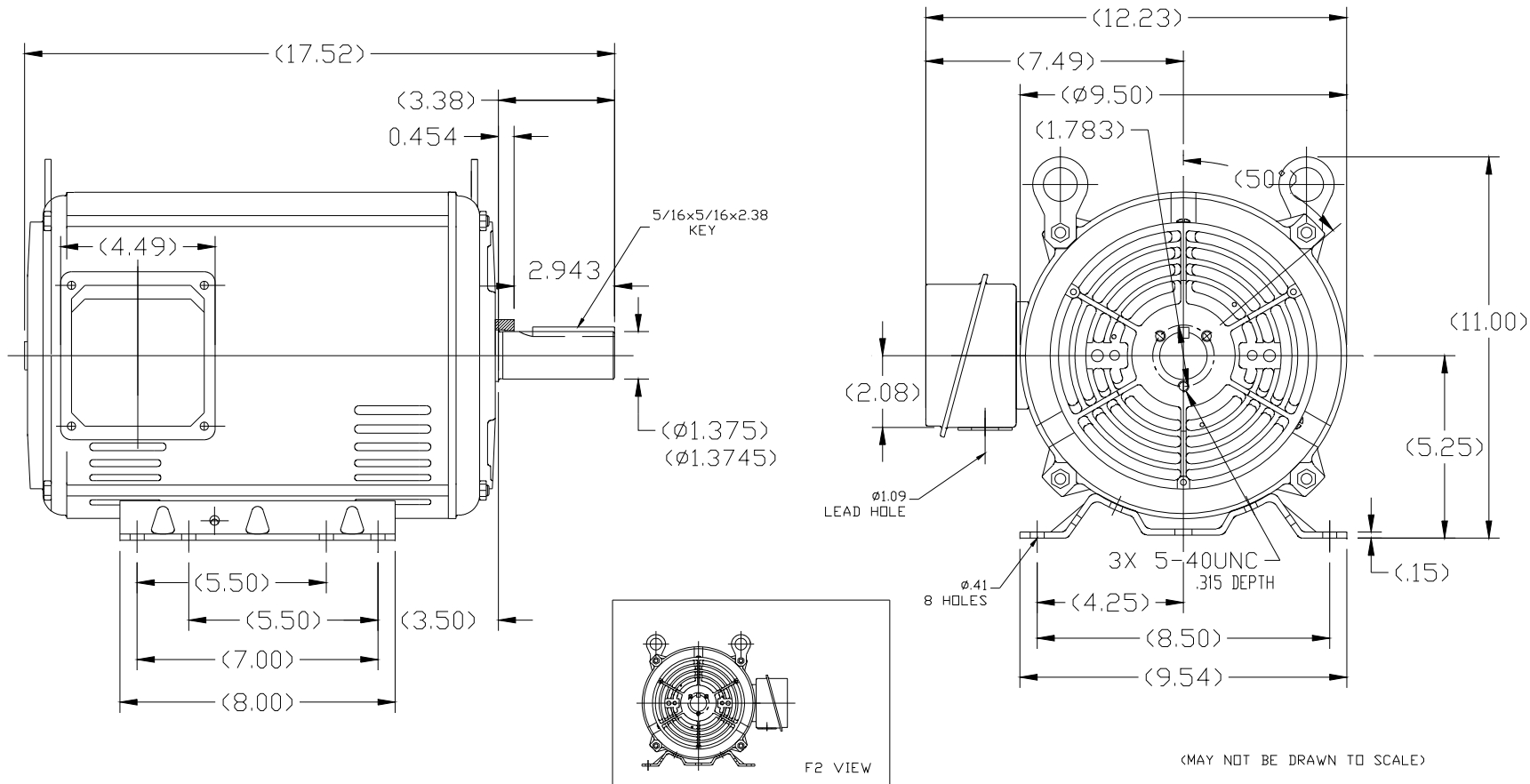

		TOLERANCES UNLESS SPECIFIED		REGAL REGAL-BELOIT CORPORATION		DRAWN ZKW 04-16-2015	
		DEC.	INCHES			CHK ZL 04-16-2015	
		X	±.1			APPD ZYH 04-16-2015	
		XX	±.03	TITLE	OUTLINE		SCALE
		XXX	±.005		213/215T ODP-ROLLED STEEL		REF
03	F2 VIEW ADDED PER ECO-0162175	NK	02-20-19	VY	XXXX	±.0005	MAT'L
NO.	REVISION		BY & DATE	CHK	ANG	±1/2°	FINISH
THIS DRAWING IN DESIGN AND DETAIL IS OUR PROPERTY AND MUST NOT BE USED EXCEPT IN CONNECTION WITH OUR WORK ALL RIGHTS OF DESIGN AND INVENTION ARE RESERVED THIS IS AN ELECTRONICALLY GENERATED DOCUMENT - DO NOT SCALE THIS PRINT				RFP	CAD FILE		SS620684
				DIST	SIZE	DRAWING NO.	REV.
					B	SS620684	3



NO.	REVISION	BY & DATE	CHK	ANG	TOLERANCES UNLESS SPECIFIED		FINISH	DRAWN RM	ML	REV.	
					DEC.	INCHES					
5	CHG TO REGAL LOGO	SL 09/10/2015	AB					11/20/1990			
4	REVISED IEC NOTATIONS	MSG 11/15/2011	CMN	.X	±.1				11/21/1990		
3	ADDED IEC NOTATIONS... (U1), (V1) ETC. MU95194	MSG 5/10/2010	MJS	.XX	±.02				04/24/2003		
2	ADDED THE OPTIONAL CORD CONNECTION MU46318	RDH 04/24/2003	DRS	.XXX	±.005						
1	REDRAWN	RM 11/20/1990		.XXXX	±.0005						
THIS DRAWING IN DESIGN AND DETAIL IS OUR PROPERTY AND MUST NOT BE USED EXCEPT IN CONNECTION WITH OUR WORK ALL RIGHTS OF DESIGN AND INVENTION ARE RESERVED THIS IS AN ELECTRONICALLY GENERATED DOCUMENT - DO NOT SCALE THIS PRINT							RFP	CAD FILE ee7308	SIZE A	DRAWING NO. EE7308	PAGE OF 5
							DIST WP				



**P.O. BOX 8003
WAUSAU, WI 54401-8003
PH. 715-675-3311**

CERTIFICATION DATA SHEET

CUSTOMER:

CUSTOMER

ORDER #:

PO#:

CONN. DIAGRAM: A-EE7308

MODEL #: 213TTDBD6026 BB

OUTLINE: SS620684

CUSTOMER PART

WINDING #: HE31324018 2

#:

MOUNTING: F1/F2 CAPABLE

TYPICAL MOTOR PERFORMANCE DATA

HP	kW	SYNC. RPM	F.L. RPM	FRAME	ENCLOSURE	KVA CODE	DESIGN
7 1/2&5	5.60&3.70	1800	1766&1472	213T	DP	H	B

PH	Hz	VOLTS	AMPS	START TYPE	DUTY	INSL	S.F.	AMB°C
3	60/50	230/460&190/380	19.8/9.9&16.8/8.4	LINE OR INVERTER	CONTINUOUS	F7	1.15/1.15	40

FULL LOAD EFF:	91&90.2	3/4 LOAD EFF:	91.5	1/2 LOAD EFF:	90	GTD. EFF	90.2	ELEC. TYPE	SQ CAGE INV RATED
FULL LOAD PF:	79&75.5	3/4 LOAD PF:	72.2	1/2 LOAD PF:	60.8				

F.L. TORQUE	LOCKED ROTOR AMPS	L.R. TORQUE	B.D. TORQUE	F.L. RISE°C
22.3 LB-FT	120 / 60	44 LB-FT 197 %	57 LB-FT 256 %	40

SOUND PRESSURE @ 3 FT.	SOUND POWER	ROTOR WK^2	MAX. WK^2	SAFE STALL TIME	STARTS / HOUR	APPROX. MOTOR WGT
47 dBA	57 dBA	9.8 LB-FT^2	50 LB-FT^2	20 SEC.	2	133 LBS.

***** SUPPLEMENTAL INFORMATION *****

DE BRACKET TYPE	ODE BRACKET TYPE	MOUNT TYPE	ORIENTATION	SEVERE DUTY	HAZARDOUS LOCATION	DRIP COVER	SCREENS	PAINT
STANDARD	STANDARD	RIGID	HORIZONTAL	FALSE	NONE	FALSE	NONE	BLUE (ENAMEL)

BEARINGS		GREASE	SHAFT TYPE	SPECIAL DE	SPECIAL ODE	SHAFT MATERIAL	FRAME MATERIAL
DE	ODE	POLYREX EM	T	NONE	NONE	1045 HOT ROLLED (C-204)	ROLLED STEEL
BALL	BALL						
6307	6206						

THERMO-PROTECTORS				THERMISTORS	CONTROL	SPACE HEATERS
THERMOSTATS	PROTECTORS	WDG RTDs	BRG RTDs			
NONE	NOT	NONE	NONE	NONE	FALSE	NONE VOLTS

* N O T E S *	INVERTER TORQUE: CONSTANT 2:1/VARIABLE 10:1 INV. HP SPEED RANGE: NONE ENCODER: NONE NONE NONE NONE NONE PPR BRAKE: NONE NONE NONE P/N NONE NONE NONE NONE FT-LB NONE V NONE Hz
---	--

PREPARED BY: Anusha Muthyala
DATE: 09/24/2019 01:10:40 AM
 FORM 3531 REV.3 02/07/99
 ** Subject to change without notice.

Data Sheet

213TTDBD6026

Date: 7/15/2020
Customer: _____
Attention: _____
Submitted by: _____



Submittal

Data @ 460 V

Motor Load Data